

AIR OIL COOLER

Olaer A-LHC with hydraulic motor - Technical specification

For selection of the ideal oil cooler, find out required cooling capacity
 oil flow
 oil temperature
 max air temperature
 or use our calculation program.

A-LHC 007 - A-LHC 023

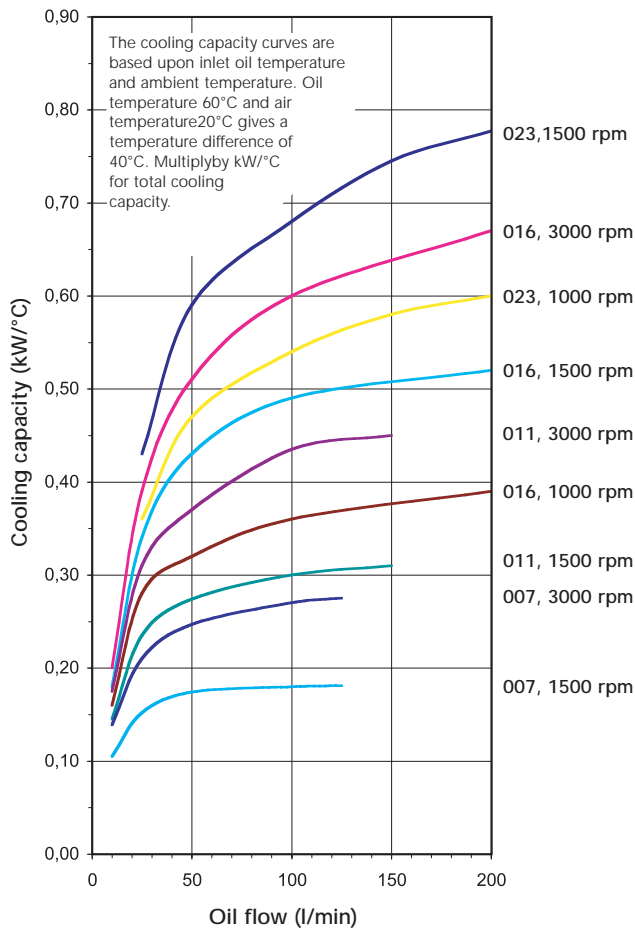

A-LHC 033 - A-LHC 112

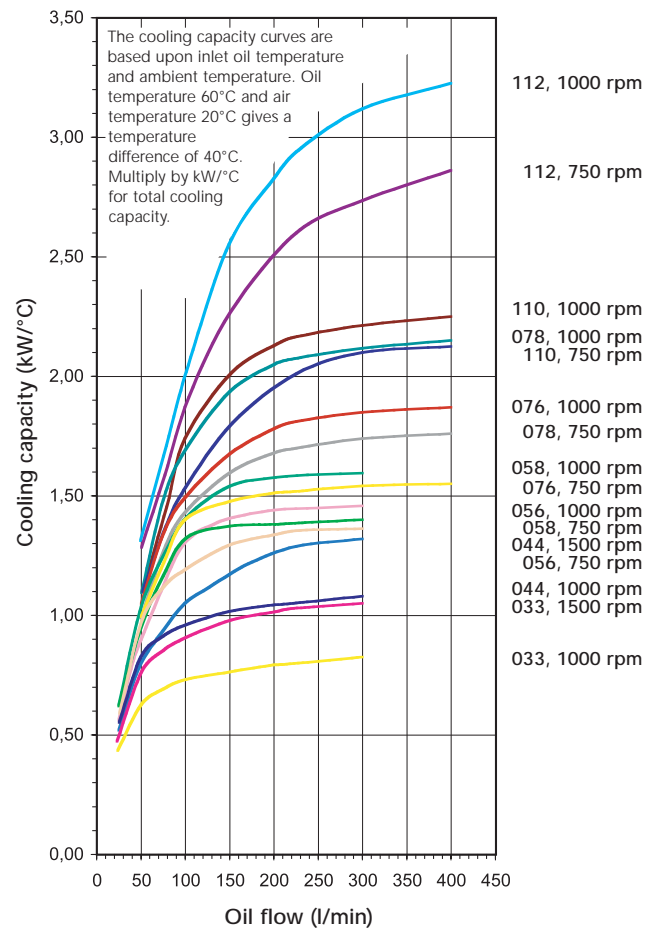

Pressure drop at 30 cSt (single-pass)

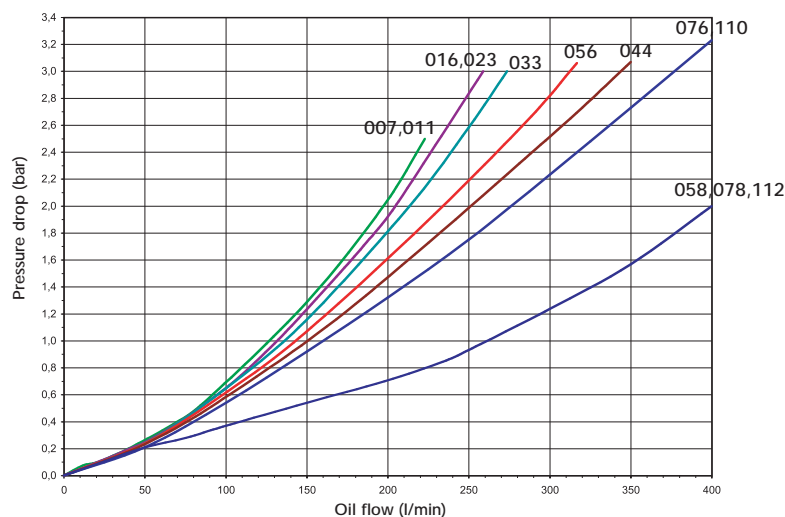

General drawing

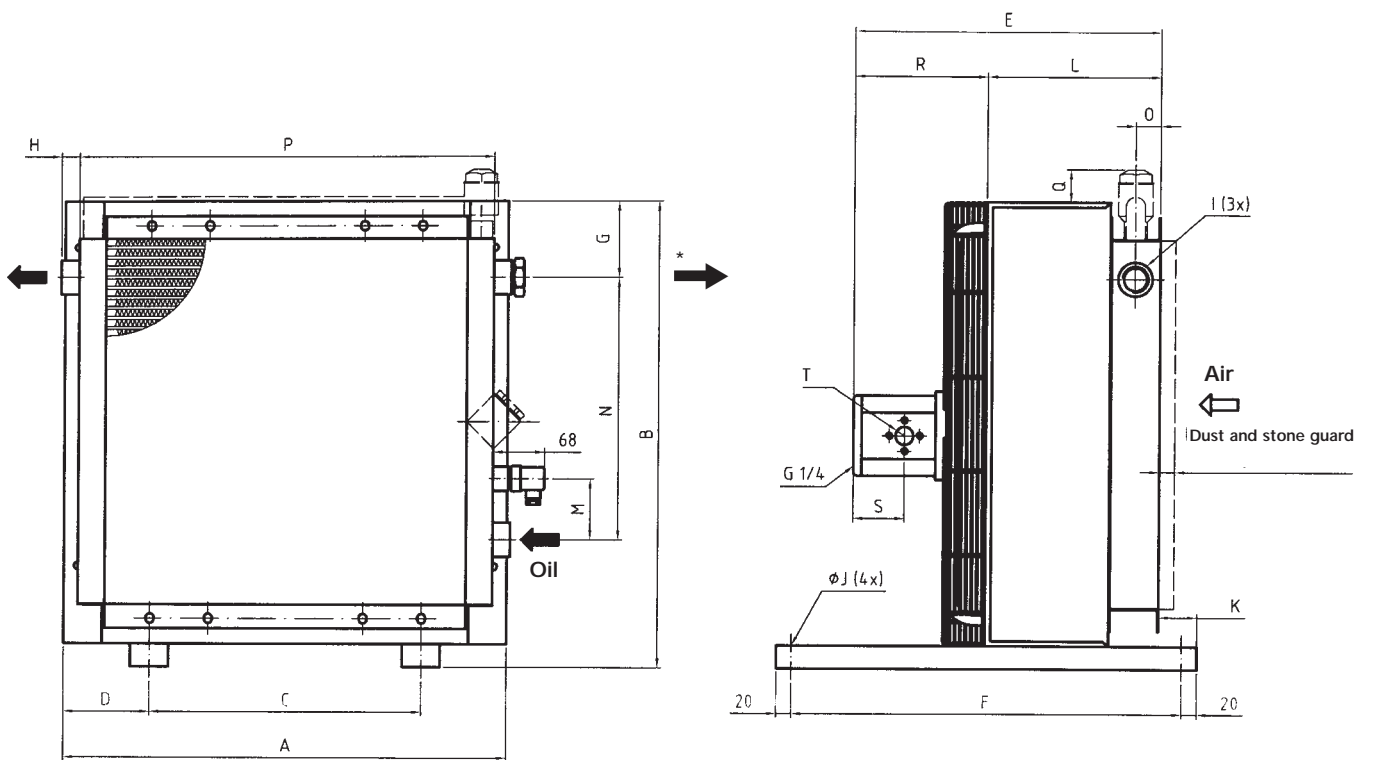

* Oil outlet when a by-pass valve type T or a two pass is used

Type	Fan rpm	Air flow m ³ /s	Fan performance kW	Weight ca kg	Max. rpm	Acoustic pressure level dB(A) 1 m*
A-LHC 007	1500	0,3	0,10	10	3500	64
	3000	0,6	0,65	10	3500	79
A-LHC 011	1500	0,5	0,20	15	3500	69
	3000	0,9	1,50	15	3500	83
A-LHC 016	1000	0,5	0,10	18	3350	63
	1500	0,8	0,35	18	3350	73
	3000	1,5	2,50	18	3350	86
A-LHC 023	1000	0,8	0,15	30	2840	66
	1500	1,2	0,50	30	2840	77
A-LHC 033	1000	1,7	0,65	40	2350	75
	1500	2,5	2,00	40	2350	85
A-LHC 044	1000	2,1	0,65	56	2350	77
	1500	3,1	2,00	56	2350	86
A-LHC 056	750	2,5	0,75	70	1850	74
	1000	3,3	1,80	70	1850	82
A-LHC 058	750	2,1	0,75	77	1850	75
	1000	2,9	1,80	77	1850	83
A-LHC 076	750	3,0	0,70	105	1690	80
	1000	4,0	1,60	105	1690	87
A-LHC 078	750	2,7	0,70	111	1690	81
	1000	3,7	1,60	111	1690	88
A-LHC 110	750	5,3	1,70	117	1440	85
	1000	7,1	4,00	117	1440	91
A-LHC 112	750	4,5	1,70	125	1440	86
	1000	6,1	4,00	125	1440	92

* Noise level tolerance ± 3 dB(A)

Dimensions

Type	A	B	C	D	E	F	G	H	I	J	K	L	M	N	O	P	Q*	Motor selection
A-LHC 007	365	395	203	81	R+L	510	103	23	G1	9	50	190	80	160	33	330	42	A-F
A-LHC 011	440	470	203	119	R+L	510	106	23	G1	9	50	215	80	230	33	400	39	A-F
A-LHC 016	496	526	203	147	R+L	510	100	23	G1	9	50	240	80	230	33	464	45	A-F
A-LHC 023	580	610	356	112	R+L	510	101	23	G1	9	50	265	80	305	33	543	44	A-F
A-LHC 033	692	722	356	168	R+L	510	103	25	G1½	9	50	240	80	406	33	635	43	A-F
A-LHC 044	692	866	356	168	R+L	510	87	25	G1½	9	50	265	80	584	33	635	59	A-F
A-LHC 056	868	898	508	180	R+L	510	102	25	G1½	9	50	290	80	584	33	802	44	A-F
A-LHC 058	868	898	508	180	R+L	510	102	31	G2	9	30	310	100	584	43	802	44	A-F
A-LHC 076	1022	1052	518	252	R+L	610	101	31	G1½	14	70	315	100	821	33	940	45	B-F
A-LHC 078	1022	1052	518	252	R+L	610	101	31	G2	14	50	335	100	821	43	940	45	B-F
A-LHC 110	1185	1215	600	293	R+L	610	100	31	G2	14	70	340	100	985	33	1130	46	D-F
A-LHC 112	1185	1215	600	293	R+L	610	100	31	G2	14	50	360	100	985	43	1130	46	D-F

* "Q" When selecting a by-pass valve type S

Motor type	Displacement (cm ³ /r)	R 007-023	R 033-112	S	T Connection	Max. working pressure (bar)
A	8,4	107	211	52,5	G½	210
B	10,8	111	215	52,5	G½	210
C	14,4	117	221	55,5	G¾	210
D	16,8	121	225	59,5	G¾	210
E	19,2	125	229	59,5	G¾	210
F	25,2	135	239	66,5	G¾	160

Ordering key for Olaer A-LHC air oil cooler.
When ordering every item should be specified.

A-LHC-XXX-X-XX-XXX-X-X
1 2 3 4 5 6 7

1. Air oil cooler fitted with hydraulic motor = A-LHC

2. Cooler size	
007	056
011	058
016	076
023	078
033	110
044	112

4. Thermo contact	
Without thermo contact	= 00
40°C	= 40
50°C	= 50
60°C	= 60
70°C	= 70
80°C	= 80
90°C	= 90

3. Hydraulic motor, displacement	
Without hydraulic motor	= 0
Hydraulic motor, displacement 8,4 cm ³ /r	= A
Hydraulic motor, displacement 10,8 cm ³ /r	= B
Hydraulic motor, displacement 14,4 cm ³ /r	= C
Hydraulic motor, displacement 16,8 cm ³ /r	= D
Hydraulic motor, displacement 19,2 cm ³ /r	= E
Hydraulic motor, displacement 25,2 cm ³ /r	= F
Special hydraulic motor	= X

(X: pressure, displacement, mounting dimensions etc., should be specified in text en clair)

5. Cooler matrix	
Standard	= 000
Two pass	= T00
Built-in pressure controlled by-pass valve, single-pass	
2 bar	= S20
5 bar	= S50
8 bar	= S80
Built-in pressure controlled by-pass valve, two-pass	
2 bar	= T20
5 bar	= T50
8 bar	= T80
Built-in temperature- and pressure controlled by-pass valve, single-pass	
50°C, 2.2 bar	= S25
60°C, 2.2 bar	= S26
70°C, 2.2 bar	= S27
90°C, 2.2 bar	= S29
Built-in temperature- and pressure controlled by-pass valve, two-pass	
50°C, 2.2 bar	= T25
60°C, 2.2 bar	= T26
70°C, 2.2 bar	= T27
90°C, 2.2 bar	= T29

6. Matrix guard	
Without guard	= 0
Stone guard	= S
Dust guard	= D
Dust and stone guard	= P

7. Standard/special	
Standard	= 0
Special	= Z

Example: A-LHC-016-B-50-S20-S-0

When ordering a special cooler, specify product, components, performance, dimensions etc., in text en clair
Price and time of delivery available on request.

For further information and latest modifications, please enter our web site www.olaer.com.au
To facilitate selection of the correct cooler, order Olaer's calculation programme.

Fluid compatibility	
Mineral oil	HL/HL to DIN 51524
Oil/Water emulsion	HFA, HFB to CETOP RP 77H
Water glycol	HFC to CETOP RP 77H
Phosphate ester	HFD-R to CETOP RP 77H

Material	
Matrix	Aluminium
Fan blades/hub	Glass fibre reinforced polypropylene/Aluminium
Fan housing	Steel
Fan guard	Steel
Other parts	Steel
Surface treatment	Electrostatically powder coated

Technical specification, matrix	
Maximum static working pressure	21 bar
Dynamic working pressure	14 bar. Tested according to ISO/DIS 10771-1
Limits of heat transfer	± 6 %
Maximum oil inlet temperature	120°C.

Cooling capacity curves
The cooling capacity curves in this technical sheet are based upon tests according to EN 1048 and are made using oil type ISO VG 46 at 60°C.

Consult your local Olaer company for use
<ul style="list-style-type: none"> • with oil temperature > 120°C • with oil viscosity > 100 cSt • in aggressive environments • in ambients rich in particles • at high altitudes

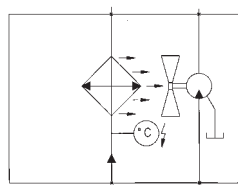

Piping diagram for
Olaer A-LHC air oil cooler

**OLAER
COOLERS**

THE COMPLETE PRODUCT RANGE



OLAER A-LAC

An air oil cooler designed for industrial applications fitted with single-phase or three-phase motor. The components have been developed in our laboratory for optimum performance.
Max. cooling capacity 130 kW at ETD 40°C.



OLAER A-LDC

An air oil cooler ideal for mobile applications because of its compact design and light weight, fitted with a 12V or a 24V DC motor. During the development of the A-LDC series of air oil coolers we developed also coolers for small cooling requirements.
Max. cooling capacity 30 kW at ETD 40°C.



OLAER A-LHC

An air oil cooler fitted with a hydraulic motor for heavy duty applications with high cooling requirement. The Olaer A-LHC air oil coolers are designed for industrial as well as mobile applications.
Max. cooling capacity 130 kW at ETD 40°C.



OLAER A-LOC

An extremely reliable air oil cooling system consisting of a matrix, a fan and a pump. Fitted with one electric motor only, this cooling system is easy to install and at a very low cost. The Olaer A-LOC cooling system is supplied fit for installation in your system.
Max. cooling capacity 45 kW at ETD 40°C.



THE OLAER GROUP AROUND THE WORLD: **AUSTRALIA** Olaer FCH. Tel: +61 2 9981 6888. **AUSTRIA** Olaer Austria GmbH. Tel: +43 7229 80306. **BELGIUM** S.A. Olaer Benelux, Tel: +32 2 466 15 15. **CZECHIA** Olaer CZ s.r.o. Tel: +42 5 47125 601-8. **DENMARK** Oiltech DK. Tel: +45 86 69 20 38. **FINLAND** Oiltech Hydraulics OY. Tel: +358 9 413 755 00. **FRANCE** Olaer Industries S.A. Tel: +33 1 41 19 17 00. **GERMANY** Olaer Industries GmbH. Tel: +49 6842 9204-0. **GREAT BRITAIN** FCH Ltd. Tel: +44 1244 535515. **INDIA** FCH India. Tel: +91 802 6533587. **ITALY** Olaer Italiana S.p.A. Tel: +39 011 991 85 11. **KOREA** Hyundai Olaer Hydraulic Co. Tel: +82 31 499 0897. **NETHERLANDS** Olaer Nederland B.V. Tel: +31 76 5412453. **NORWAY** Oiltech AS. Tel: +47 64 91 11 80. **POLAND** Oiltech Polska. Tel: +48 22 6738162. **SCHWIZERLAND** Olaer (Schweiz) AG. Tel: +41 26 492 70 00. **SOUTH AFRICA** FCH c/o Rolton Products CC. Tel: +27 11 474 3095. **SPAIN** Olaer-Oiltech Iberica SAU. Tel: +34 933 368 900. **SWEDEN** Oiltech AB. Tel: +46 8 636 07 00. **USA** Oil Air Hydraulics Inc. Tel: +1 713 937 89 00.

Please note: Being a renowned manufacturer of cooling systems for hydraulics, Olaer is constantly seeking ways to improve the specification and design of its products and alterations take place continually. The products in this brochure may be updated, altered in any way or discontinued, without prior notice.